

BALDOR[®] • RELIANCE 

Product Information Packet

ECR92004TR-4

200HP, 1785RPM, 3PH, 60HZ, 447T, A44106M, TEFC

Part Detail							
Revision:	H	Status:	PRD/A	Change #:		Proprietary:	No
Type:	AC	Elec. Spec:	A44WG5112	CD Diagram:	416820-036	Mfg Plant:	
Mech. Spec:		Layout:	617427-355	Poles:	04	Created Date:	02-06-2015
Base:		Eff. Date:	03-12-2020	Leads:	3#1/0 (02 per group)		

Specs			
Catalog Number:	ECR92004TR-4	Heater Indicator:	No Heater
Enclosure:	TEFC	Insulation Class:	F
Frame:	447T	Inverter Code:	Inverter Ready
Frame Material:	Iron	KVA Code:	H
Output @ Frequency:	200.000 HP @ 60 HZ	Lifting Lugs:	No Lifting Lugs
Synchronous Speed @ Frequency:	1800 RPM @ 60 HZ	Motor Lead Quantity/Wire Size:	6 @ 1/0 AWG
Voltage @ Frequency:	460.0 V @ 60 HZ	Motor Type:	A44106M
XP Class and Group:	None	Mounting Arrangement:	F1
XP Division:	Not Applicable	Power Factor:	87
Agency Approvals:	CSA EEV	Product Family:	Crusher / Chipper
Auxillary Box:	No Auxillary Box	Pulley End Bearing Type:	Roller
Base Indicator:	Rigid	Pulley Face Code:	Standard
Bearing Grease Type:	Mobil SHC 220 (Athens Only)	Shaft Ground Indicator:	No Shaft Grounding
Constant Torque Speed Range:	15-60	Shaft Rotation:	Reversible
Current @ Voltage:	225.000 A @ 460.0 V	Shaft Slinger Indicator:	Shaft Slinger
Design Code:	A	Speed Code:	Single Speed
Drip Cover:	No Drip Cover	Motor Standards:	NEMA
Duty Rating:	CONT	Starting Method:	Direct on line

Feedback Device:	NO FEEDBACK	Thermal Device - Bearing:	None
		Thermal Device - Winding:	None

Nameplate 000613007PV										
CAT NO	ECR92004TR-4			SPEC NO.	P44G1813					
HP	200	AMPS	225	VOLTS	460		DESIGN	A		
RPM	1785	RPM MAX	3600	HZ	60	AMB	40	SF	1.15	
D.E. BRG.DATA	NU222			O.D.E. BRG.DATA	6318		PH	3	DUTY	CONT
FRAME	447T	I.P.	55	TYPE	P	ENCL	TEFC	CODE	H	
POWER FACTOR	87	3/4 LOAD EFF.			96.4		NEMA NOM EFFICIENCY			96.2
CHP HZ	60-90	CT HZ	15-60	VT HZ	6-60					
SER.NO.				MOTOR WEIGHT						

Nameplate NP2496L

MOBIL SHC -220 GREASE

Parts List		
Part Number	Description	Quantity
SA293598	SA P44G1813	1.000 EA
RA279691	RA P44G1813	1.000 EA
000613007PV	SS NP, CRUSHER DUTY, EMBOSSED,MAIN MOTOR	1.000 EA
000692000FF	N/P	1.000 EA
000692000RT	N/P	1.000 EA
000692000VD	LABEL WARNING	1.000 EA
NP2496L	MOTOR LUBE NAMEPLATE	1.000 EA
032018008CK	HHCS 3/8-16X1L PLATED	4.000 EA
032018020FK	HHCS 3/4-10X2-1/2 PLTD.	4.000 EA
032018030DK	HHCS 1/2-13X3-3/4 PLTD.	3.000 EA
032620016LA	SOCKET SET SCREW-449	3.000 EA
034017014AB	LCKW 3/8 STD. PLATED	4.000 EA
034180014DA	KEY 1/4X1/4X1-3/4 L	1.000 EA
034530064AB	P/NIP 1/8 X 8" L Pipe Nipple	1.000 EA
034530064BB	P/NIP 1/4X8 PLATED	1.000 EA
034631002AB	BUSH 1/4 TO 1/8 PLTD.	1.000 EA
035000001G	GREASE RELIEF FITTING, ALEMITE 317400	1.000 EA
034690005AB	PPLG 3/4 PLATED	2.000 EA
078549001DA	FAN 400 078549001F	1.000 EA
083199082RA	G28 SHORT FAN COVER W/BAFFLE ASSEMBLY	1.000 EA
089490099A	G28 BRKT 089490098WCA KB	1.000 EA
415045002A	SLGR	1.000 EA
415072001B	CLAMP	1.000 EA
415096002A	CPLG 1/8 HEX TYPE	1.000 EA

Parts List (continued)		
Part Number	Description	Quantity
418151014G	RETAIN RING	1.000 EA
032018004BK	HHCS 5/16-18X1/2 PLATED	3.000 EA
032018020FK	HHCS 3/4-10X2-1/2 PLTD.	4.000 EA
032018030DK	HHCS 1/2-13X3-3/4 PLTD.	3.000 EA
034017013AB	LCKW 5/16 STD. PLATED	3.000 EA
034530036AB	P/NIP 1/8 X4-1/2 Yellow Zinc46114-BM	1.000 EA
034530036BB	P/NIP 1/4X4-1/2 GALV.	1.000 EA
034631002AB	BUSH 1/4 TO 1/8 PLTD.	1.000 EA
035000001G	GREASE RELIEF FITTING, ALEMITE 317400	1.000 EA
089490101A	G28 BRKT 089490100WCA	1.000 EA
415045002D	SLGR - 440 V1T45B	1.000 EA
415096002A	CPLG 1/8 HEX TYPE	1.000 EA
415915007G	GASK, LAC	1.000 FT
418151014H	RETAIN RING	1.000 EA
702623013A	THERMAL BARRIER -- G28 -- BRACKET MTD	1.000 EA
032018008BK	HHCS 5/16-18X1L PLATED	4.000 EA
032018008DK	HHCS 1/2-13X1 PLATED	4.000 EA
033512004LB	HHTTS 1/4-20X1/2 PLTD.	1.000 EA
035000001A	ALFTG 1/8" 1610-BL	1.000 EA
035000001A	ALFTG 1/8" 1610-BL	1.000 EA
067053014A	GASK 440	1.000 EA
076870000B	+CBCST BLKT - 440	1.000 EA
076871000A	+CBOX CVR BLKT - 449	1.000 EA
406056007A	GASKET, 440	1.000 EA

Product Information Packet: ECR92004TR-4 - 200HP,1785RPM,3PH,60HZ,447T,A44106M,TEFC

406099000A	PLUG - FAN COVER 320-440	1.000 EA
415000103D	T/LUG #4AWG-1/0AWG W/HOLE FOR .250 BOLT	1.000 EA
418150003A	GREASE FITTING CAP	1.000 EA
418150003A	GREASE FITTING CAP	1.000 EA
033775004EA	DRSCR #6-1/4 304 S.S.	2.000 EA
034180054KA	7/8 SQ X 6.75 KEY	1.000 EA
MG1025G96	WILKOFASST SG, 779.7048, MOUSE GRAY #7048	0.500 GA
421948051	LABEL, MYLAR	1.000 EA
000613006PU	N/P (RELEASE QTY 10,000) UL CSA LABEL	1.000 EA
034001016AB	WSHR .562ID 1.375OD .109	1.000 EA
034001014AB	FLAT WASHER 3/8"PLATED	1.000 EA
032018028CK	HHCS 3/8-16X3-1/2 PLTD.	1.000 EA
604797001R	440 FR. ROLLER BEARING MOTOR SHAFT	1.000 EA
604799003C	PLASTIC BAG 42X32X46	1.000 EA
033300014AC	HEX NUT, SHIPPING - 400	2.000 EA
034001016AB	WSHR .562ID 1.375OD .109	2.000 EA
034001014AB	FLAT WASHER 3/8"PLATED	2.000 EA
032510026D	CARRIAGE BOLT - 440	2.000 EA
604797032	447/449 WIDE SHIPPING SKID	1.000 EA
004824015AP	GREASE MOBILITH SHC 220	1.160 LB
412118006A	DRAIN	2.000 EA

S/O	FRAME	HP	TYPE	PHASE/ HERTZ	RPM	VOLTS
	447T	200	P	3/60	1785	460
AMPS	DUTY	AMB °C/ INSUL	S.F.	NEMA DESIGN	CODE LETTER	ENCLOSURE
225	CONT	40/F	1.15	A	H	TEFC
E/S	ROTOR	TEST S.O.	TEST DATE	STATOR RES. @25 °C OHMS (BETWEEN LINES)		
-	418143034VE	---	---	.0160		

PERFORMANCE

LOAD	HP	AMPERES	RPM	% POWER FACTOR	% EFFICIENCY
NO LOAD	0	62.2	1800	4.61	0
1/4	50.0	82.7	1797	60.5	93.7
2/4	100	122	1793	79.7	95.9
3/4	150	171	1790	85.0	96.3
4/4	200	225	1786	86.5	96.2
5/4	250	280	1782	87.2	95.9

SPEED TORQUE

	RPM	% FULL LOAD TORQUE	TORQUE LB.-FT.	AMPERES
LOCKED ROTOR	0	244	1436	1669
PULL UP	1450	198	1162	1187
BREAKDOWN	1733	253	1490	762
FULL LOAD	1786	100	588	225

AMPERES SHOWN FOR 460 VOLT CONNECTION. IF OTHER CONNECTIONS ARE AVAILABLE, THE AMPERES WILL VARY INVERSELY WITH THE RATED VOLTAGE.

CALCULATED DATA
XE MOTOR-NEMA NOM. EFF. 96.2 PCT.

 A MEMBER OF THE ABB GROUP	DRAWN BY: CD	AC MOTOR PERFORMANCE DATA	A44WG5112-R001 DATE ISSUED 02/05/20
	CHECKED BY: T. KELATI APPROVED BY: T. KELATI DATE: 02/05/2015		

USERCHR1

Printed on 09/26/2017 7:57 AM

REL.S.O.	447T	RPM	1785	S.F.	1.15	ROTOR	418143034VE
FRAME	447T	VOLTS	460	NEMA DESIGN	A	TEST S.O.	CALCULATED DATA
HP	200	AMPS	225	CODE LETTER	H	TEST DATE	--
TYPE	P	DUTY CONT		ENCLOSURE	TEFC	STATOR RES. @ 25°C	.0160
PHASE/HERTZ	3/60	AMB °C/INSUL	40/F	E/S	-	OHMS (BETWEEN LINES)	

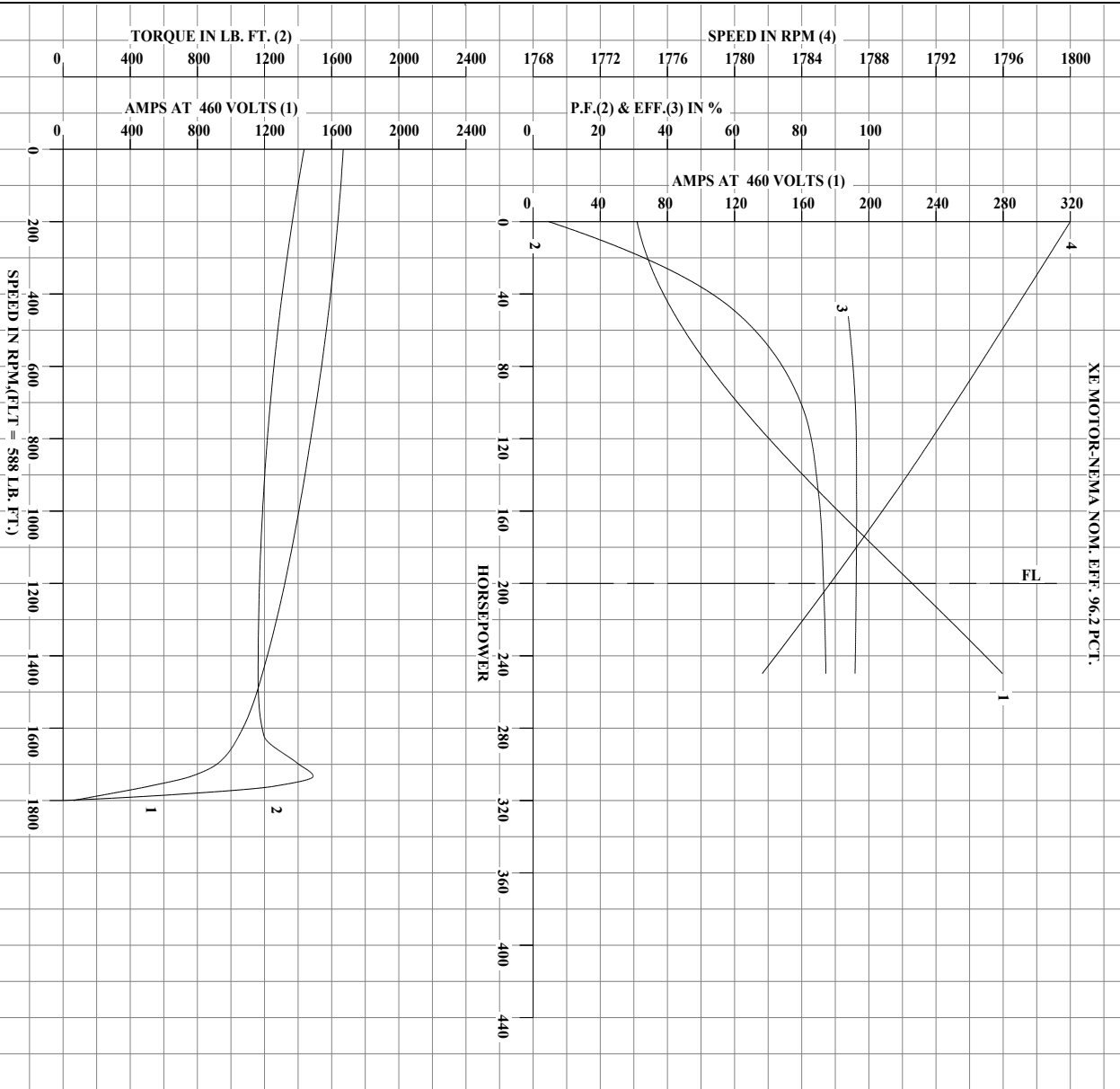

AMPERES SHOWN FOR 460 VOLT CONNECTION, IF OTHER VOLTAGE CONNECTIONS ARE AVAILABLE, THE AMPERES WILL VARY INVERSELY WITH THE RATED VOLTAGE.

<p>BALDOR A MEMBER OF THE ABB GROUP</p>	DRAWN BY: CD CHECKED BY: T.KELATI APPROVED BY: T.KELATI DATE: 02/05/2015	AC MOTOR PERFORMANCE DATA	A44WG5112-R001 ISSUE DATE: 02/05/2015
--	---	---------------------------------	--

USERCHR1

Printed on 09/26/2017 7:57 AM

REL.S.O.	447T	RPM	1785	S.F.	1.15	ROTOR	418143034VE
FRAME	200	VOLTS	460	NEMA DESIGN	A	TEST S.O.	CALCULATED DATA
HP	200	AMPS	225	CODE LETTER	H	TEST DATE	--
TYPE	P	DUTY CONT		ENCLOSURE	TEFC	STATOR RES. @ 25°C	.0160
PHASE/HERTZ	3/60	AMB °C/INSUL	40/F	E/S	-	OHMS (BETWEEN LINES)	

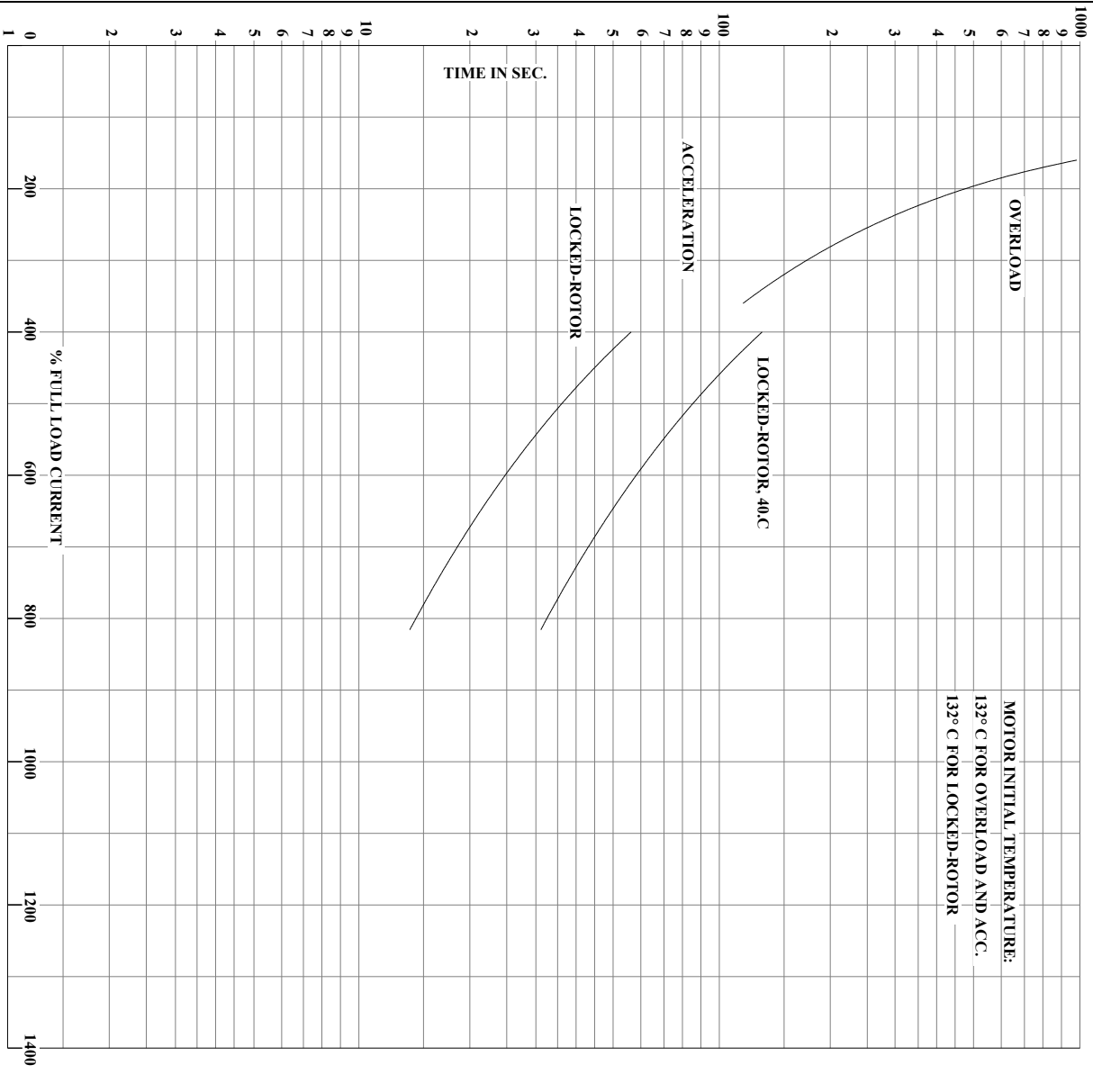

AMPERES SHOWN FOR 460 VOLT CONNECTION, IF OTHER VOLTAGE CONNECTIONS ARE AVAILABLE, THE AMPERES WILL VARY INVERSELY WITH THE RATED VOLTAGE.

 A MEMBER OF THE ABB GROUP	DRAWN BY: CD	AC MOTOR	A44WG5112-R001
	CHECKED BY: T.KELATI	PERFORMANCE	
	APPROVED BY: T.KELATI	DATA	
	DATE: 02/05/2015		ISSUE DATE: 02/05/2015

USERCHR1

Printed on 09/26/2017 7:57 AM

DUTY MASTER ALTERNATING CURRENT MOTORS

SQUIRREL-CAGE INDUCTION

ENCLOSURE: TOTALLY ENCLOSED

FRAME G447T ABOVE NEMA RATINGS

COOLING: FAN COOLED

MOUNTING: FOOT

INCLUDES 445T FRAME MOUNTING HOLES

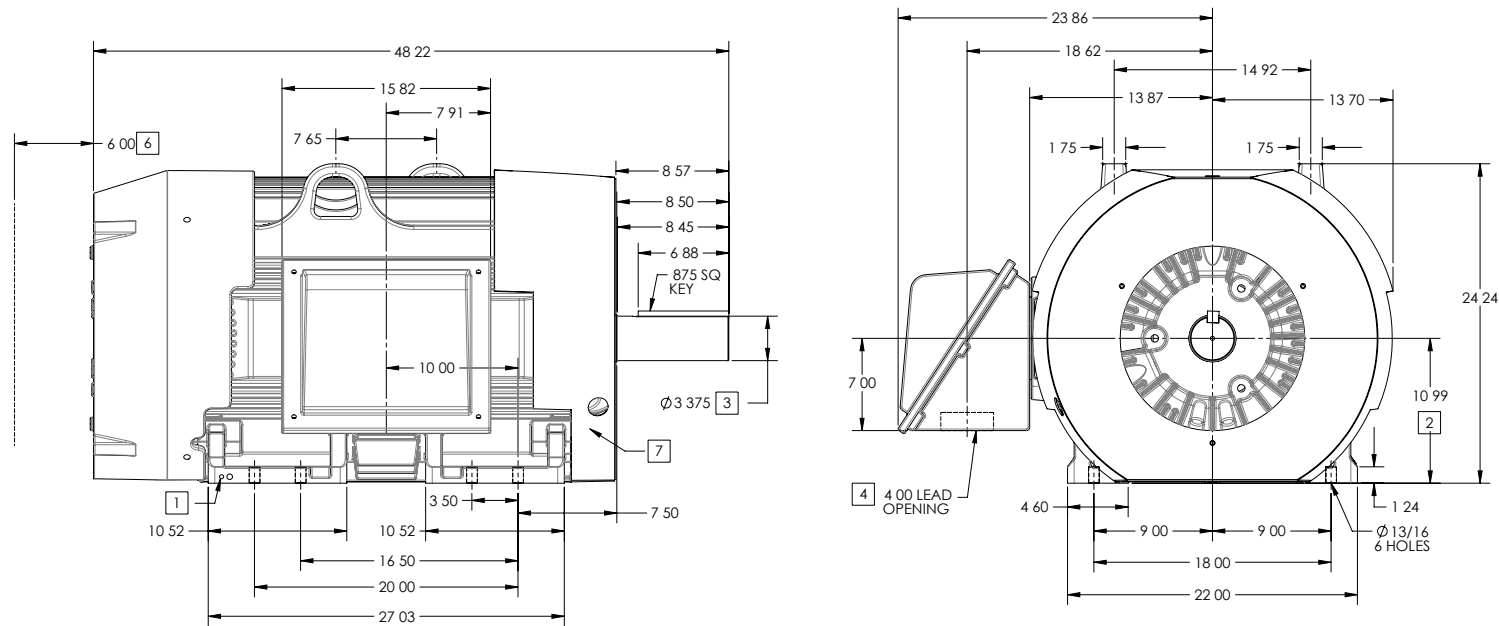

- 1 GROUND HOLES QTY 1 1/2-13 TAP; QTY 1 3/8-16 TAP
- 2 VARIES + 00 - 06
- 3 VARIES + 000 - 001
- 4 ON STANDARD MOTORS THIS IS CONDUIT SIZE ON XT AND CORROSION PROOF MOTOR THIS IS PIPE TAP
- 5 MOTOR WEIGHTS MAY VARY BY 15% DEPENDING ON RATING
- 6 OBSTRUCTION MUST NO ENCROACH ON AIR INLET
- 7 AIR DEFLECTOR INSTALLED WHEN REQUIRED

CONDUIT BOX LOCATED ON OPPOSITE SIDE WHEN F-2
 IF MOUNTING CLEARANCE DETAILS ARE REQUIRED CONSULT FACTORY
 MAXIMUM PERMISSIBLE SHAFT RUNOUT WHEN MEASURED AT END OF
 STANDARD SHAFT EXTENSION IS .003 T I R TO 5 INCH DIA

5 WEIGHT (LBS): 2515

DRIVE END AIR DEFLECTOR IS ONLY INCLUDED WHEN NECESSARY

DIMENSIONS ARE IN INCHES; SEE SHEET 2 FOR DIMENSIONS IN MILLIMETERS

CUSTOMER IS RESPONSIBLE FOR DETERMINING THAT MOTOR PERFORMANCE IS SUITABLE IN THE APPLICATION

SHEET NUMBER
1 OF 2

55E-27-355

REV.	DESC.	NEW ISSUE		
REV.	VERSION	00	REVISED 0 29 05 02 09 2015	TDR 00000088 510
MODEL NO.	617 27-355		REF	
BY	RAGGDM	Material		

BALDOR

G 7U/ 5T STD FOOTED SIDE CENTER C/B WITH AIR DEFLECTOR

DUTY MASTER ALTERNATING CURRENT MOTORS

SQUIRREL-CAGE INDUCTION

ENCLOSURE: TOTALLY ENCLOSED

FRAME G447T ABOVE NEMA RATINGS

COOLING: FAN COOLED

MOUNTING: FOOT

INCLUDES 445T FRAME MOUNTING HOLES

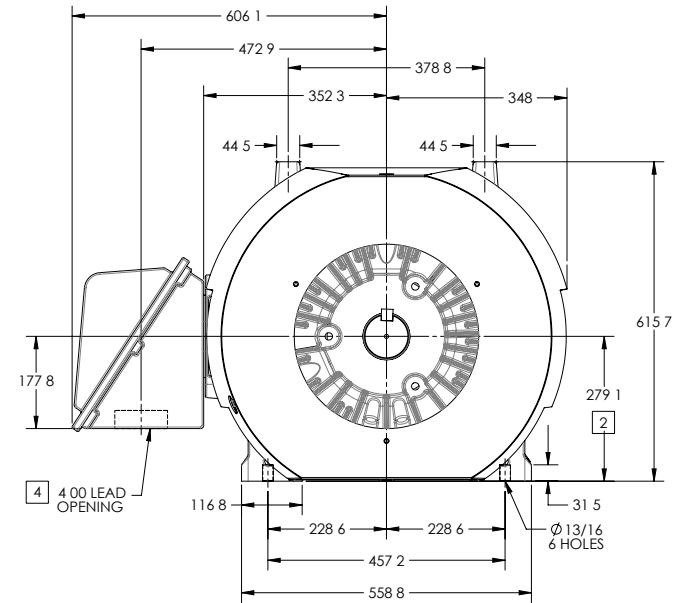
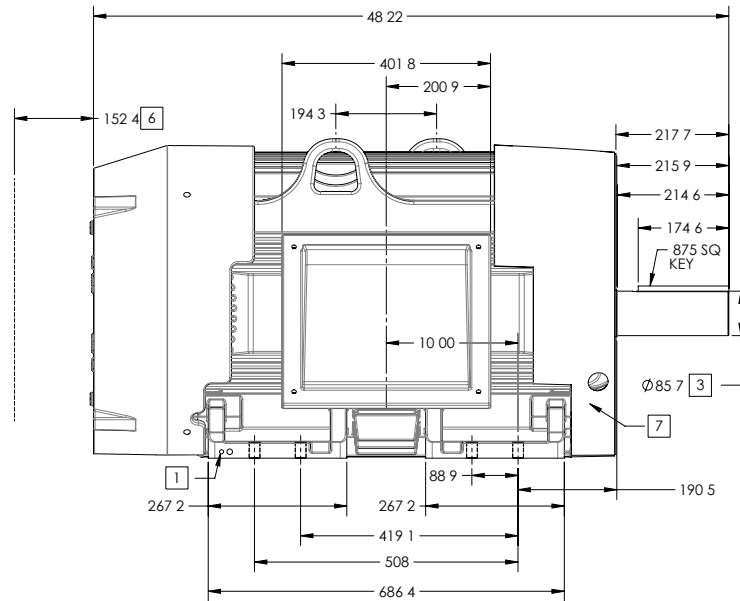

- 1 GROUND HOLES QTY 1 1/2-13 TAP; QTY 1 3/8-16 TAP
- 2 VARIES + 00 - 06
- 3 VARIES + 000 - 001
- 4 ON STANDARD MOTORS THIS IS CONDUIT SIZE ON XT AND CORROSION PROOF MOTOR THIS IS PIPE TAP
- 5 MOTOR WEIGHTS MAY VARY BY 15% DEPENDING ON RATING
- 6 OBSTRUCTION MUST NO ENCROACH ON AIR INLET
- 7 AIR DEFLECTOR INSTALLED WHEN REQUIRED

CONDUIT BOX LOCATED ON OPPOSITE SIDE WHEN F-2
 IF MOUNTING CLEARANCE DETAILS ARE REQUIRED CONSULT FACTORY
 MAXIMUM PERMISSIBLE SHAFT RUNOUT WHEN MEASURED AT END OF
 STANDARD SHAFT EXTENSION IS .08 MM T I R TO 127 MM DIA

5 WEIGHT (KGS): 1140

DRIVE END AIR DEFLECTOR IS ONLY INCLUDED WHEN NECESSARY

DIMENSIONS ARE IN MILLIMETERS; SEE SHEET 1 FOR DIMENSIONS IN INCHES

CUSTOMER IS RESPONSIBLE FOR DETERMINING THAT MOTOR PERFORMANCE IS SUITABLE IN THE APPLICATION

REV.	DESC.	NEW ISSUE		
REV.	VERSION	00	REVISED 0 29 05 02 09 2015	TDR 00000088 510
MODEL NO.	617 27-355		REF	
BY	RAGGDM	Material		

BALDOR

G 7U / 5T STD FOOTED SIDE CENTER C/B WITH AIR DEFLECTOR

55E-27-355

617427-355

416820-036

A-C MOTOR
 CONNECTION DIAGRAM
 STANDARD 3 LEAD CONNECTED

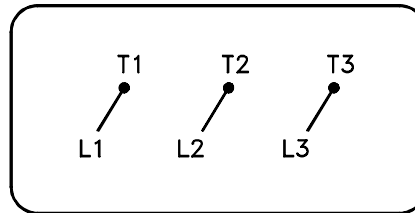

(N.P. 1575-BA)

416820-036

REV. DESC: LOADED TO BUS, C/R 335225		
REV. LTR: -	VERSION: 00	TDR: 000000538207
FILE: \MGA\00000\682	REVISED: 11:54:06 04/30/2010	
MTL: -	BY: RAGRA	

BALDOR

CONN DIAG - STANDARD 3 LEAD

SH 1 of 1

Marketing maintained PDF of MN408:

[MN408?ManNumber=MN408](#)

Marketing maintained PDF of MN416:

[MN416?ManNumber=MN416](#)